

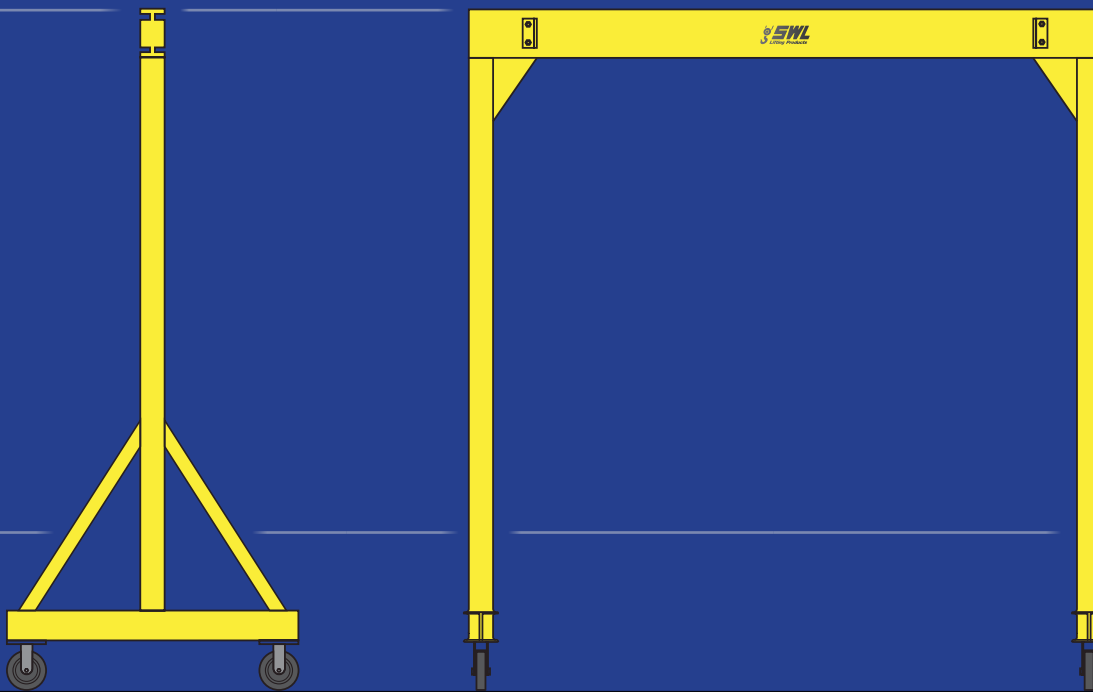

Gantry Crane

Fixed Height



Specifications

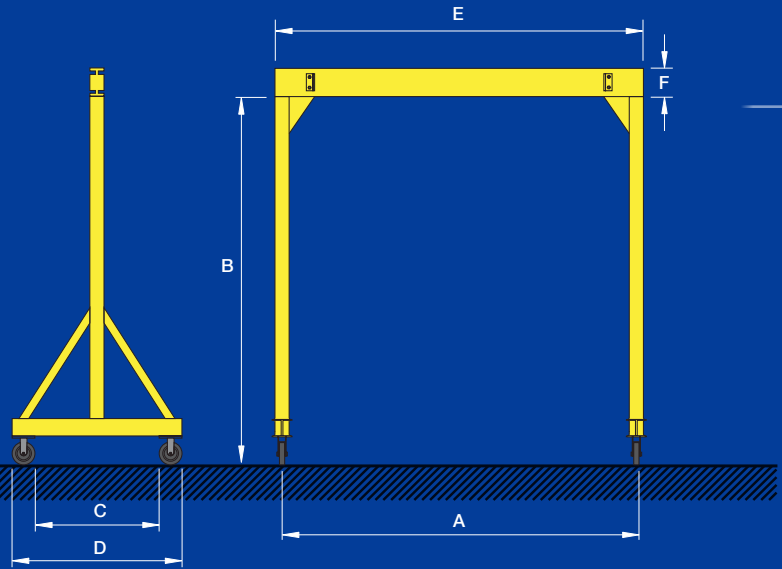

| Model | Capacity [tons] | Span A | Height B | C | D | E | F | Shipping Weight [Approx. lbs.] | |
|-------------|-----------------|--------|----------|-----|-----|--------|--------|--------------------------------|------|
| 1TFHG-10-10 | 1 Ton | 10' | 10' | 36" | 41" | 10' 6" | 8" | 700 | |
| 1TFHG-10-12 | | | 12' | 42" | 47" | 10' 6" | 8" | 750 | |
| 1TFHG-10-15 | | | 15' | 48" | 53" | 10' 6" | 8" | 810 | |
| 1TFHG-10-10 | | 12' | 12' | 10' | 36" | 41" | 12' 6" | 8" | 740 |
| 1TFHG-10-12 | | | | 12' | 42" | 47" | 12' 6" | 8" | 790 |
| 1TFHG-10-15 | | | | 15' | 48" | 53" | 12' 6" | 8" | 850 |
| 1TFHG-10-10 | | 15' | 15' | 10' | 36" | 41" | 15' 6" | 10" | 900 |
| 1TFHG-10-12 | | | | 12' | 42" | 47" | 15' 6" | 10" | 940 |
| 1TFHG-10-15 | | | | 15' | 48" | 53" | 15' 6" | 10" | 1000 |
| 1TFHG-10-10 | | 20' | 20' | 10' | 36" | 41" | 20' 6" | 10" | 1025 |
| 1TFHG-10-12 | | | | 12' | 42" | 47" | 20' 6" | 10" | 1070 |
| 1TFHG-10-15 | | | | 15' | 48" | 53" | 20' 6" | 10" | 1130 |
| 2TFHG-10-10 | 2 Ton | 10' | 10' | 36" | 43" | 10' 6" | 8" | 800 | |
| 2TFHG-10-12 | | | 12' | 42" | 49" | 10' 6" | 8" | 870 | |
| 2TFHG-10-15 | | | 15' | 48" | 55" | 10' 6" | 8" | 970 | |
| 2TFHG-10-10 | | 12' | 12' | 10' | 36" | 41" | 12' 6" | 8" | 840 |
| 2TFHG-10-12 | | | | 12' | 42" | 47" | 12' 6" | 8" | 910 |
| 2TFHG-10-15 | | | | 15' | 48" | 53" | 12' 6" | 8" | 1000 |
| 2TFHG-10-10 | | 15' | 15' | 10' | 36" | 43" | 15' 6" | 10" | 1020 |
| 2TFHG-10-12 | | | | 12' | 42" | 49" | 15' 6" | 10" | 1060 |
| 2TFHG-10-15 | | | | 15' | 48" | 55" | 15' 6" | 10" | 1150 |
| 2TFHG-10-10 | | 20' | 20' | 10' | 36" | 43" | 20' 6" | 10 ½ " | 1356 |
| 2TFHG-10-12 | | | | 12' | 42" | 49" | 20' 6" | 10 ½ " | 1430 |
| 2TFHG-10-15 | | | | 15' | 48" | 55" | 20' 6" | 10 ½ " | 1525 |
| 3TFHG-10-10 | 3 Ton | 10' | 10' | 36" | 44" | 10' 8" | 10" | 890 | |
| 3TFHG-10-12 | | | 12' | 42" | 50" | 10' 8" | 10" | 925 | |
| 3TFHG-10-15 | | | 15' | 48" | 56" | 10' 8" | 10" | 980 | |
| 3TFHG-12-10 | | 12' | 12' | 10' | 36" | 41" | 12' 8" | 8" | 945 |
| 3TFHG-12-12 | | | | 12' | 42" | 47" | 12' 8" | 8" | 980 |
| 3TFHG-12-15 | | | | 15' | 48" | 53" | 12' 8" | 8" | 1040 |

Continued on next page →

Gantry Crane Fixed Height

Specifications (cont.)

| Model | Capacity [tons] | Span A | Height B | C | D | E | F | Shipping Weight [Approx. lbs.] |
|-------------|-----------------|--------|----------|-----|-----|--------|--------|--------------------------------|
| 3TFHG-15-10 | 3 Ton | 15' | 10' | 36" | 44" | 15' 8" | 12" | 1030 |
| 3TFHG-15-12 | | | 12' | 42" | 50" | 15' 8" | 12" | 1070 |
| 3TFHG-15-15 | | | 15' | 48" | 56" | 15' 8" | 12" | 1125 |
| 3TFHG-20-10 | | 20' | 10' | 36" | 44" | 20' 8" | 15" | 1525 |
| 3TFHG-20-12 | | | 12' | 42" | 50" | 20' 8" | 15" | 1575 |
| 3TFHG-20-15 | | | 15' | 48" | 56" | 20' 8" | 15" | 1645 |
| 5TFHG-10-10 | 5 Ton | 10' | 10' | 36" | 44" | 10-9" | 12" | 1620 |
| 5TFHG-10-12 | | | 12' | 42" | 50" | 11' 5" | 12" | 1685 |
| 5TFHG-10-15 | | | 15' | 48" | 56" | 11' 5" | 12" | 1800 |
| 5TFHG-12-10 | | 12' | 10' | 36" | 44" | 12' 9" | 12" | 1725 |
| 5TFHG-12-12 | | | 12' | 42" | 50" | 12' 9" | 12" | 1800 |
| 5TFHG-12-15 | | | 15' | 48" | 56" | 12' 9" | 12" | 1915 |
| 5TFHG-15-10 | | 15' | 10' | 36" | 44" | 15' 9" | 15" | 1900 |
| 5TFHG-15-12 | | | 12' | 42" | 50" | 15' 9" | 15" | 1970 |
| 5TFHG-15-15 | | | 15' | 48" | 56" | 15' 9" | 15" | 2075 |
| 5TFHG-20-10 | | 20' | 10' | 36" | 44" | 20' 9" | 15 ½ " | 2180 |
| 2TFHG-20-12 | | | 12' | 42" | 50" | 20' 9" | 15 ½ " | 2255 |
| 5TFHG-20-15 | | | 15' | 48" | 56" | 20' 9" | 15 ½ " | 2370 |

*Dimensions may be subject to change at time of order based on material available.

All our gantry cranes have been manufactured by our parent company The Dressor Group Ltd. Dressor is a CWB certified welding company certified to CSA W 59 and all gantries are welded to CSA W47.1 and are pre-engineered to the highest possible standards including a 15% impact allowance for an electric hoist.

Unless otherwise specified, all gantry cranes come with four swivel castors, two of them with a locking brake.



Distributed by:

